

Envirokeeper

Infiltration Applications

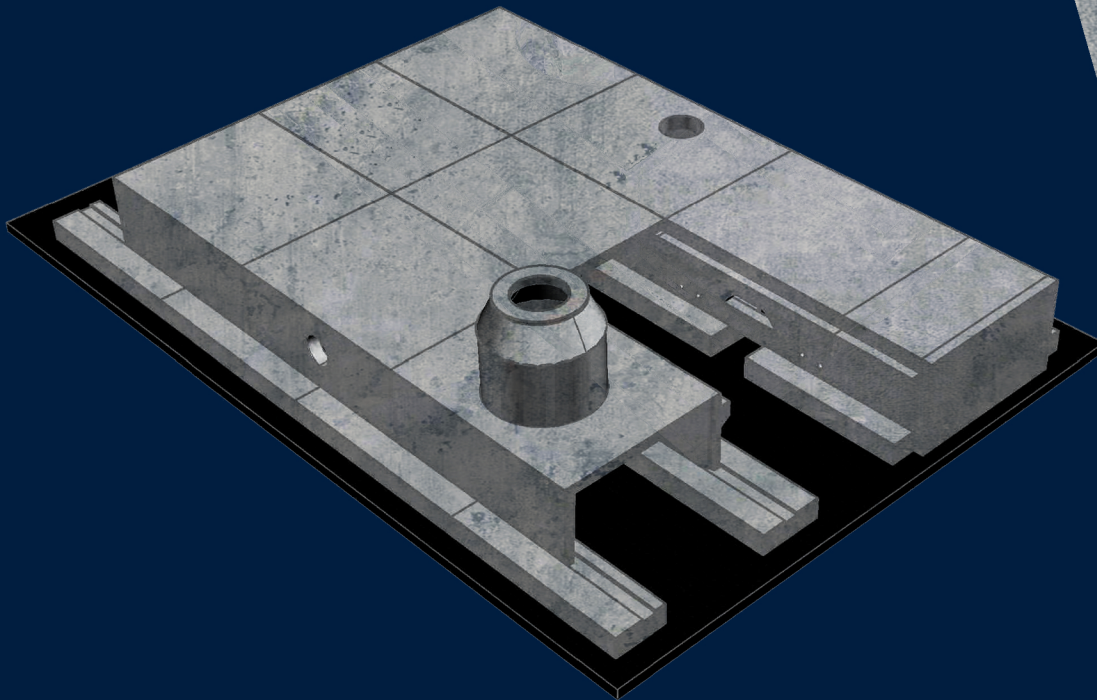

VANHOOSECO[®]
PRECAST



Modular Concrete Stormwater Management System

www.vanhooseco.com

System Overview

With the increasing need for better water and storm water management practices the need for better storm water management systems has become evident. Increasing population and urbanization has created a need for the ability to direct and store not only peak storm water flow, but also to divert water to prevent erosion and provide for water treatment, as well as harvesting storm water for irrigation and ground water restoration.

While a variety of systems have existed for many years, they tend to have been adapted from existing systems that have been modified in their usage. Still others provide only temporary, short term lifespans that require high maintenance or periodic replacement. There is an ever present need to provide a system that not only meets the water management needs, but also provides a low impact, low maintenance, and high strength solution. EnvirOkeeper is that system.

EnvirOkeeper is a modular precast, pre-engineered, reinforced concrete in ground detention, retention, harvesting, & infiltration system designed for maximum efficiency and minimal environmental impact. It is available in a variety of widths, and heights up to 16 feet. Because it is manufactured in plant controlled conditions, it allows for simultaneous construction of the modules and the site work, reducing overall construction time. It also allows for higher quality concrete, tighter tolerances, & better finish quality.

This system has many benefits and advantages over conventional storm water systems. These include:

1. **Low environmental impact:** The system utilizes reinforced concrete. The raw materials of concrete and steel are often composed of post-consumer recycled materials. Additionally concrete is inert in the environment.
2. **High Durability:** Concrete has a well-documented long term life cycle.
3. **High Strength:** The reinforced concrete modules can be design for heavy traffic loadings with minimal cover or greater cover with more depth. This can provide for easier access for maintenance and can reclaim land for uses such as parking lots, land that was previously lost to open detention ponds.
4. **Flexibility:** The system is adaptable to not only detention and retention, but also infiltration and harvesting. The modules can even be designed for water conveyance as bottomless culverts with strip footings.
5. **Adaptability:** The modules can be configured for minimal depth over larger areas or maximum depth over smaller footprints depending on site conditions and requirements. Module sizes are variable rather than fixed by the forming system.
6. **Portability:** The forming system is portable and can be used in plant controlled conditions or where shipping costs are prohibitive it can be shipped to the site for on-site casting, reducing overall cost.
7. **Cost Savings:** Because the system is designed specifically for storm water management it can utilize the minimal amount of materials required by the site and loading conditions.
8. **Water Treatment:** The modules can be supplied with a variety of different filter media to control suspended solids, oil & grease, and nitrates.
9. **Dependability:** Reinforced concrete has been used for decades and has a proven record and performance.
10. **Efficiency:** The forming system is designed to consider maximum efficiency during the setup, casting, and form stripping processes. Form break-down is kept to a minimum by making use of “positive draft” of the interior and exterior vertical surfaces, thus saving time and labor costs.

As mentioned above, the EnvirOkeeper system offers many benefits over traditional storm water management systems that can pay off for not only the contractors and developers, but also for the building owners, tenants, and more importantly the environment.

The System

The secret to the system is the module and its accessories and components, and their ability to be configured in many different ways to take advantage of each sites and project's unique needs and demands.

While other systems have fixed or moderately variable sizes, the EnvirOkeeper system is customizable in size and shape. This makes it ideally suited to taking on the various tasks required by modern storm water management.

The Components:

- A) **The Modules:** The modules are essentially a “U-shaped” continuous channel with interlocking joints. They can be configured in various height and span combinations as well as wall and slab thicknesses. The modules can be used upright, overturned, or stacked in a “clam-shell” configuration. Primary structural reinforcement is either reinforcing steel bars or welded wire reinforcement. These can also be used in combination with each other to create the most cost effective scheme. The walls can be designed with a variety of sizes and shapes of equalization openings. Continuous bearing ledges may also be provided for support of secondary structural “spanning” members.
- B) **Flat slabs:** Flat slabs can be designed and provided as top slab members spanning between modules or base slab members depending on the desired configuration. These may be conventionally reinforced like the modules of pre-stressed for longer spans.
- C) **Strip Footings:** For infiltration units continuous or semi-continuous strip footings may be provided to allow for an “open bottom” basin. These footings are provided with a recess in the top for better fit and rigidity of the members.
- D) **Weir Walls:** Weir walls can be provided integrally cast into the modules where required.
- E) **End closures:** End closures can be provided to cap runs of modules.
- F) **Outlet Control structures and flow Dissipaters:** Downstream modules can be outfitted with a variety of internal structures to control the flow out of the system.
- G) **Filter Media:** Hanging baskets and filter layers can be designed and incorporated into the system based on need.

As is clearly evident above, the EnvirOkeeper System is unique it providing the most efficient, cost effective, and durable solution in water management systems.

Envirokeeper

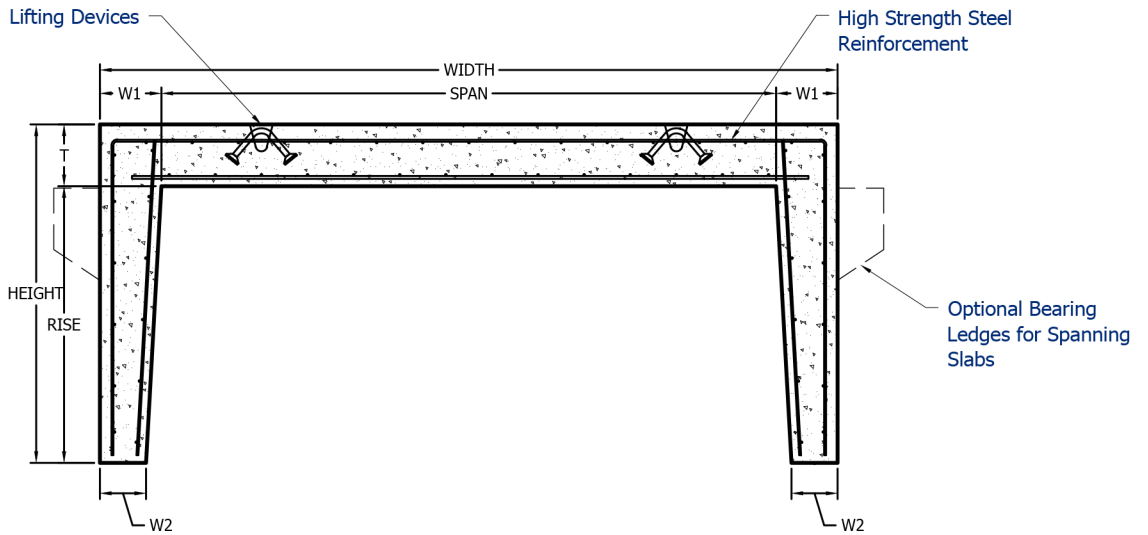

Section of the Basic Module

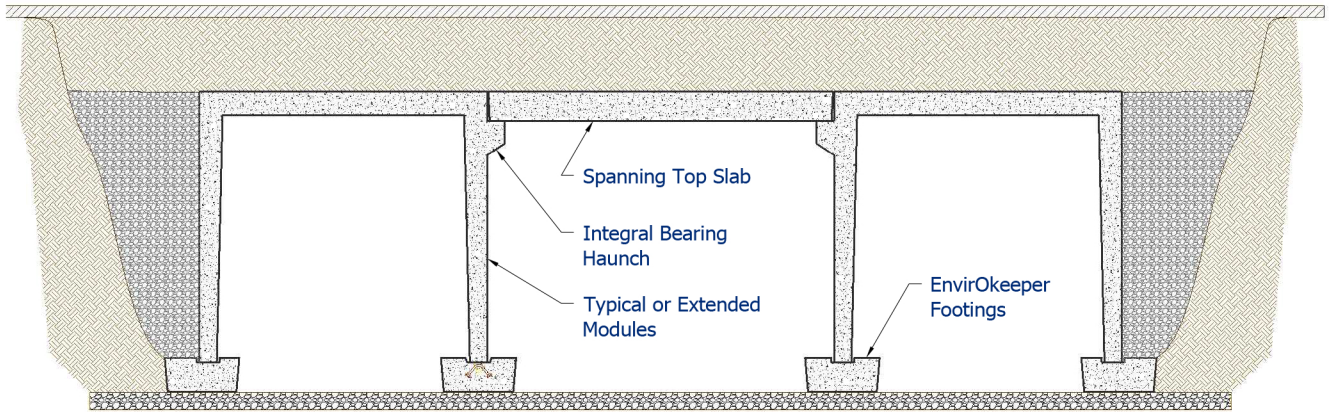

Modules with Footings & Spanning Slabs

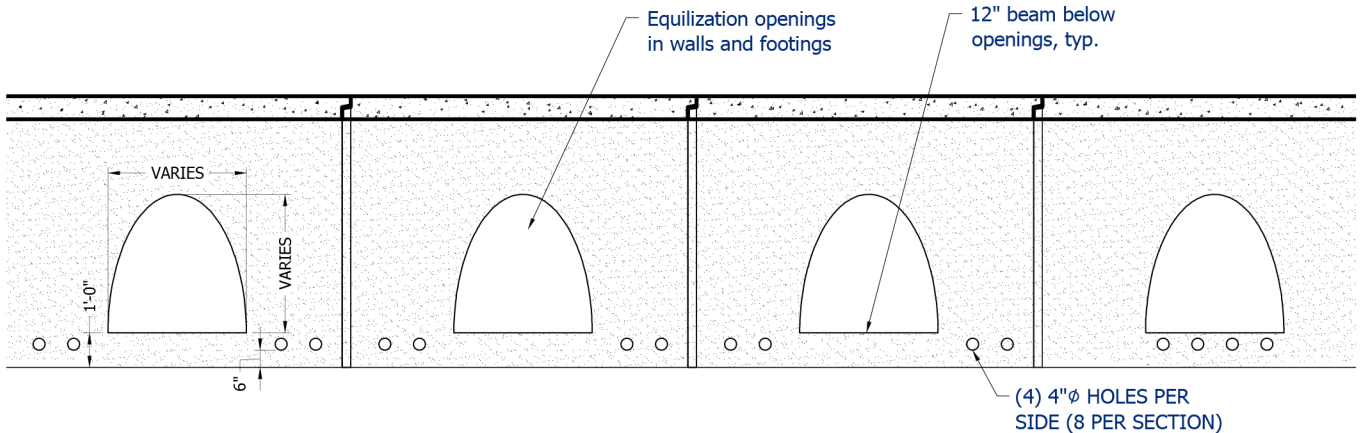

Modules with Footings & Spanning Slabs

Envirokeeper

The EnvirOkeeper System is simple and fast to install, decreasing construction time and speeding up the completion time of your project. For speed and accuracy call VANHOOSECO Precast about your water management needs.

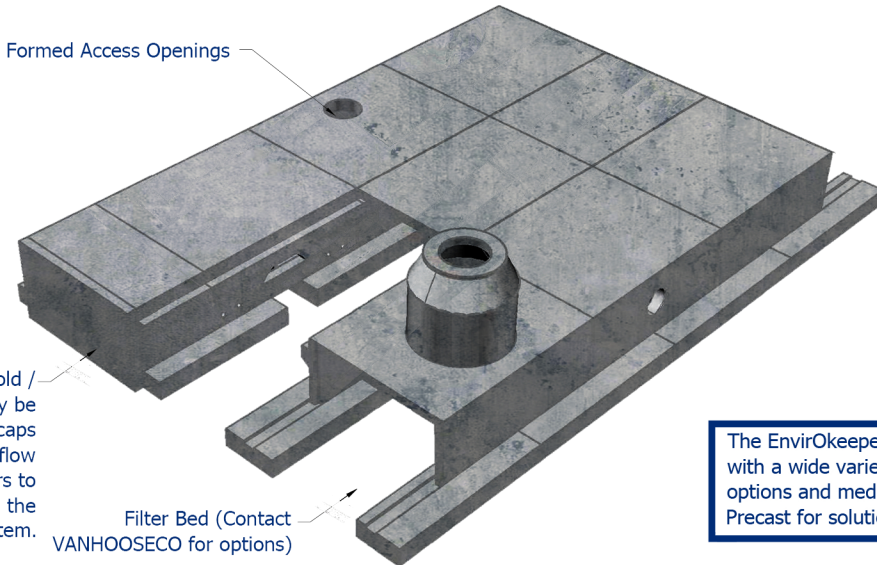

Modules on Base Slabs with Intermediate Spanning Top Slab

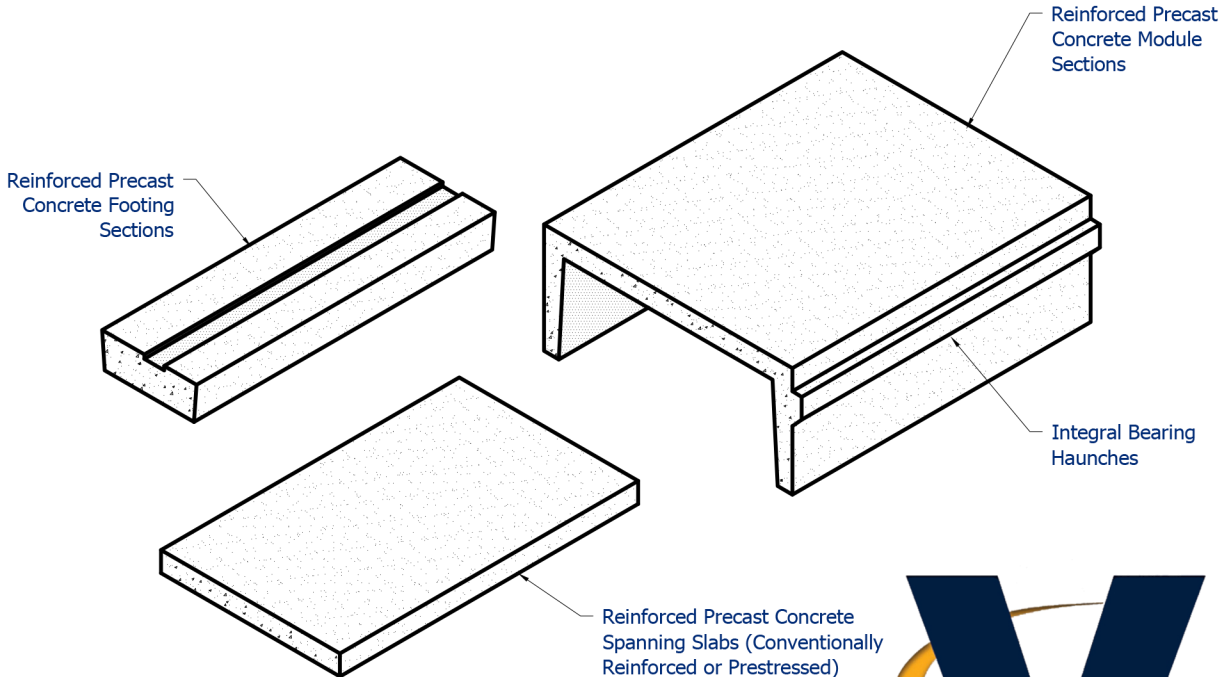

Infiltration Components

Vanhooseco® Precast
244 Blair Bend Drive
Loudon, TN 37774
865-458-3998
www.vanhooseco.com

